



*HIGH QUALITY SERVICE  
GUARANTEED DELIVERY  
COMPETITIVE PRICE  
FLEXIBILITY IN ORDERS  
CUSTOMER SATISFACTION  
SAFETY FIRST*



HEAD OFFICE / FACTORY

Address. #14, 405beon gil, Gamchunhang-ro, Saha-gu, Busan, Korea  
Tel. +82-51-262-3554 / Fax. +82-51-262-3556 / e-mail : cmkorea@sunjinckm.com

# FISH PROCESSING SYSTEM CM KOREA

## Craft & Machinery

Manufacture and Repair Fish & Crab Processing  
Equipment Design and Install Fishery Equipment & Conveyor  
for Factory Automation



## Company Information

CM KOREA Co., Ltd. was established in 1st of Aug. 2013, as one of Sunjin family.  
CM KOREA Co., Ltd. is specialized in design, manufacture, installation  
of fishery equipment for factory automation such as conveyor system.  
CM KOREA Co., Ltd. has been developed by rich experience, highly  
skilled repair, renovative work.

## Business Area

**FISH PROCESSING EQUIPMENT**  
**CRAB PROCESSING EQUIPMENT**  
**FACTORY AUTOMATION SYSTEM**  
**CONVEYOR SYSTEM**





## CEO Greetings

At CM Korea, we are in pursuit in making the world better place by extending our technology and practicing our social responsibilities by returning part of our gains back to the community.

Our vision aims at providing the necessities for the pursuit of betterment of the customer by using innovative engineering technology. As such, we are proud of our technical know-how based on the long lasting vessel repair experience. We have met the demand of customers by developing effective, productive process.

CM Korea continues to pursue the ultimate goal of bringing happiness, which is established on trust and respect, to our customers and to all of our staff members. The people at CM Korea share the same vision of a true minded engineer and are committed to working to their best ability to exceed expectations of the customers and society.

The display board features several sections:

- QUIET DIESEL™ SERIES**
  - Most technically advanced marine generators available
  - Reliable products
  - Low noise
  - Efficient for your digital world
  - High performance for quality power
  - Wide range of applications
  - Worldwide distributor/dealer network in the industry
- THE COMPONENTS BUSINESS**
  - Cummins Emission Solutions: a global leader in designing, manufacturing and integrating exhaust aftertreatment technology for the medium-duty, heavy-duty and high-horsepower engine markets.
  - Cummins Filtration: designs, manufactures and services air, fuel, oil and lube filtration, chemical and exhaust system cleaning products.
  - Cummins Fuel Systems: designs, develops and manufactures fuel systems and remanufactures Deere/Cummins engines.
  - Cummins Turbo Technologies: designs and manufactures turbochargers to boost power, and water pumps for diesel engines.
- CUMMINS DISTRIBUTION BUSINESS**
  - Seventeen Company-owned distribution and 500+ partner work through 250+ local, worldwide selling and delivery Cummins-branded products and services.

Images of various machinery and components are scattered throughout the board.

# History & Human Resources

История и Организация

# Factory Layout

Общий вид Завода



**2013**

Aug  
CM KOREA Co., LTD founded in Gupyeong-dong, Saha-gu Busan

**2014**

Oct  
Completed and moved into a new factory in Gupyeong-dong, Saha-gu Busan  
Jun  
Obtained a license to build an R&D Center from the Korea Industrial Technology Association

**2015**

Oct Obtain ISO9001:2008  
May Obtained a license to bid for competition from Public Procurements Service  
Apr Registered a Women enterprise to the Korean Women Entrepreneurs Association  
Mar Patents applied for Basket & Hanger for Crab processing system

**2001**

Jan  
Established Sunjin Entech Co., Ltd

**2007**

Jan  
Dae-rim Shipbuilding Co., Ltd. merged to Sunjin Shipbuilding Co., Ltd.

**2010**

Apr  
Established Sunjin Sherwood Co., Ltd.

**2013**

Jul  
Sunjin Sherwood Co., Ltd. changed the company name to Sunjin Entech Co., Ltd.

**1962**

Sep  
Established Shinyoung Shipping Co., Ltd

**1963**

Apr  
Established Dae-rim Shipbuilding Co., Ltd.

**1995**

Jan  
Established Sunjin Shipbuilding Co., Ltd.

**1997**

Jan  
Established Sunjin Jonghap Co., Ltd.

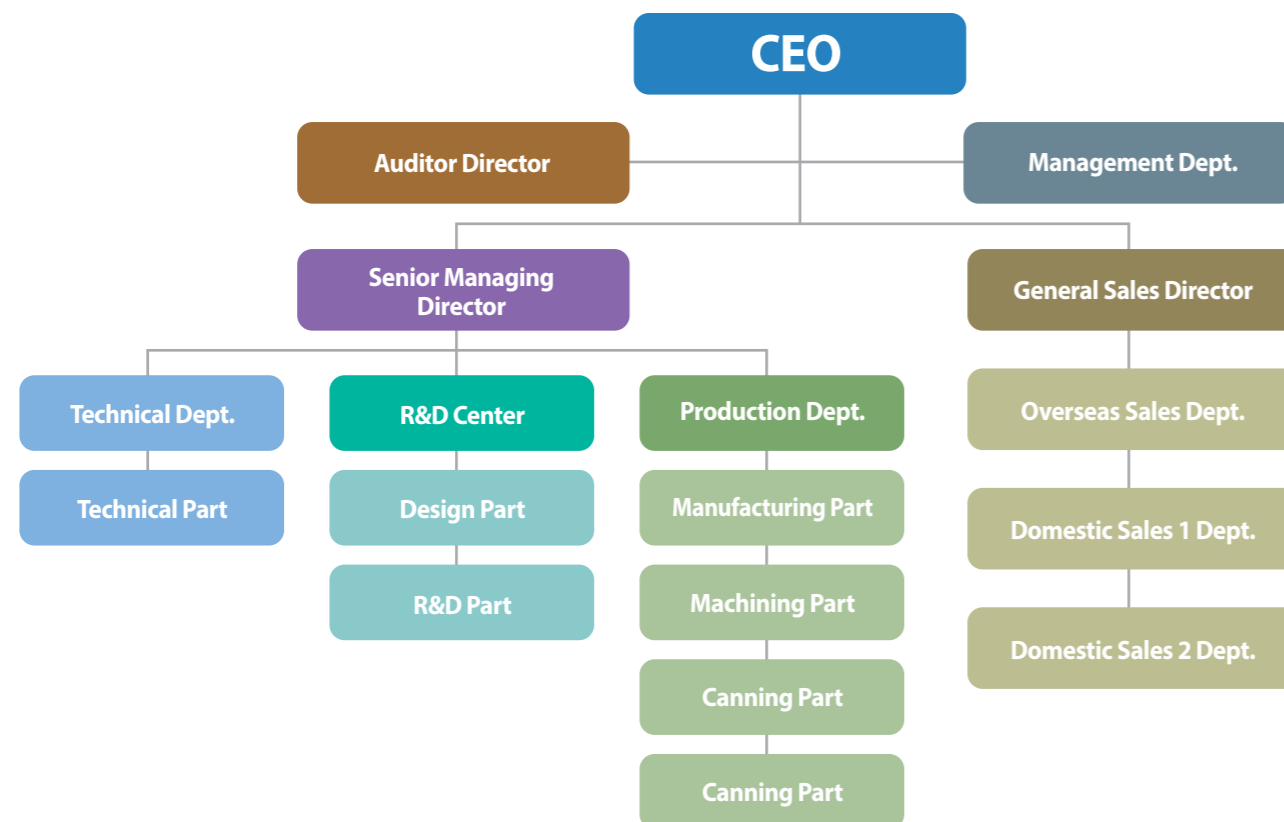

Director Office



Reception Hall



Dinning Room

# Main Proprietary Equipment

Главное Оборудование



No.	NAME	EQUIPMENT	SPECIFICATION	Remark	No.	NAME	EQUIPMENT	SPECIFICATION	Remark
1	MECHANICAL CUTTING MACHINE		DAI IN ENGINEERING DHS-6026 2014.11.13	1 SET	10	CUTTING MACHINE		YONG SU ENGINEERING YS - 16A 2013.08.12	1 SET
2	HYDRAULIC OFFSET MACHINE		DAI IN ENGINEERING DHB-6032 2014.11.13	1 SET	11	DRILLING MACHINE		WOO SUNG ENGINEERING WSD - 19 2013.08.12	3 SET
3	MILLING MACHINE		HWA CHUN MACHINE. HMTH-1300 2013.08.12	1 SET	12	BENCH GRIDER		HAP DONG WELDER HD-500AD 2013.08.12	1 SET
4	LATHE		HWA CHUN MACHINE. HL-460-1500 2013.08.12	2 SET	13	TURN TABLE		HAN IL CORP. HIL - G - 501 2013.08.12	1 SET
5	AC/DC TIG WELDER		HAP DONG WELDER HD-500AD, 500DT, 350DT 2013.08.12	500AD : 4SET 500DT : 2SET 350DT : 2SET 350AD : 2SET 300AD : 2SET	14	FORK LIFT TRUCK		DONG YANG TRAD. D - WELCO 2013.08.12	1 SET
6	AIR PLASMA CUTTER		HAP DONG WELDER 150P, 80P 2013.08.12	150P : 3SET 80P : 6SET	15	JIB CRANE		KT ELECTRIC LTH - 490 (1 ton) 2014.10.30	1 SET
7	CO2 ARC WELDER		D-WEL TECH D-WEL 500 2013.08.12	1 SET	16	HOIST CRANE		BANDO HOIST 5TON / 2.8TON 2014.10.30	5t: 4 SET 2.8t: 2 SET
8	ARC WELDER		HAP DONG WELDER HAP DONG - 220 2013.08.12	DC ARC: 4SET HD-ARC: 1SET (350A)	17	COMPRESSOR TANK		CM KOREA HART-1.5 2014.09.19	1 SET
9	DC PULSE MIG INVERTER		HAP DONG WELDER HAP DONG 350A 2013.08.12	1 SET					

# Business Record

Бизнес Рекорд



No.	Project Name	Description	Remarks
1	MYS MARI	1. LINE HAULER REPAIR / SIZE: 1100B X 1700L X 1350H, 1 SET 2. KEYSTONE CONVEYOR / SIZE: 500B X 3100L(SUS304), 1 SET 3. BELT CONVEYOR / SIZE: 450B X 2600L(SUS304), 1 SET SIZE: 450B X 3500L(SUS304), 1 SET SIZE: 450B X 4500L(SUS304), 1 SET 4. HEAD CUTTING M/C / SIZE : 500B X 1500L X 200B, 1 SET 5. FISH BUNKER / SIZE : 1000B X 1400L X 1000H, 1 SET 6. WORKING TABLE / DRESSING TABLE / PACKING TABLE, 1 LOT 7. CHUTE / CRUSHER / OFFAL BIN, 1 LOT	09. 2013
2	MYS DATTA	1. PUSHER-PRESS CART : DISMANTLE & REFIT 2. WIRE TENSIONER - LOAD CART : RENEW AS SAMPLE 3. FACTORY CONVEYOR : REPAIR 4. IMPELLER - MILL : DISMANTLE, CHECK & REPAIR AS PER CHECK 5. HAMMER : MANUFACTURE AS SAMPLE & RENEW 6. HOLD CONVEYOR & CHUTE : REPAIR 7. REDUCER OF LOADING CART : OVER HAUL 8. FISH PAN : REPAIR	05. 2014
3	MYS MENSHIKOVA	1. FISH PAN : REPAIR	05. 2014
4	MYS LEVENORNA	1. FISH BUNKER CYLINDER : RENEW 2. OFFAL CHUTE (BAADER M/C) : MANUFATURE 3. SORTING M/C : REPAIR 4. VERTICAL CYLINDER (SORTING M/C) : RENEW 5. BAG WARTP : MANUFACTURE 6. BELT OF FISH HOLD CONVEYOR : RENEW BELT 7. CONVEYOR : REMODEL	06. 2014
5	ALTAIR	1. VARIATOR - OVERHAUL 2. SHAFT SEAL PACKING OF DRYER : RENEW 3. MILL : REPAIR, SUBMIT TO CREW (OVERHAUL) 4. STEAM VENTILATION : DISASSEMBLE/ASSEMBLE SUBMIT TO CREW 5. REDUCER (OVERHAUL) : MILL PRESS, PRESS AND DRYER	06. 2014
6	OSTROV SAKHALIN	1. PORTABLE CONVEYOR : MANUFACTURE 2. P.V.C BELT : SUPPLY	06. 2014
7	SHANS 102	1. BUTCHERING M/C : REPAIR 2. INCLINE CONVEYOR : REPAIR	04. 2014
8	SAGAL	1. HEAD CUTTING CONVEYOR : REPAIR & RENEW 2. FILLET M/C : REPAIR 3. SCAN CONVEYOR PART : MANUFACTURE & REPAIR	10. 2014
9	BEREZINA	1. STEEL PART IN FISH FACTORY : RENEW & REMODEL 2. HYD' PART IN FISH FACTORY : RENEW & REMODEL 3. ELECTRIC PART IN FISH FACTOR : RENEW & REMODEL	09. 2014
10	BORODINO	4. WOODEN PART IN FISH FACTOR : RENEW & REMODEL 5. TECHNICAL PART IN FISH FACTOR : RENEW & REMODEL	
11	MYS VELIKAN	1. LINE HAULER & SIDE ROLLER : REPAIR 2. CHUTE : MANUFACUTRE 3. TABLE : MANUFACUTRE 4. INCLINE KEYSTONE CONV : MANUFACUTRE 5. FISH BUNKER : MANUFACTURE 6. HEAD CUTTING MACHINE : MANUFACTURE 7. FISH CRUSHER : MANUFACTURE 8. INCLINE KEYSTONE CONV : MANUFACTURE 9. ROLLER CONVEYOR : MANUFACTURE 10. PAN SHELF : MANUFACTURE 11. GLAZING MACHINE : MANUFACTURE 12. SIDE ROLLER : REMODEL 13. MUSTAD EQUIP. ENTRANCE RAIL : REPAIR 14. BAIT BASKET : REMODEL 15. HOOK SEPARATOR GUIDE : MANUFACTURE 16. ROLLER CONVEYOR (LINE BELT CONVEYOR) : MANUFACTURE	01. 2015

No.	Project Name	Description	Remarks
12	PETROPAVLOVSK	1. MILL HAMMER : REPAIR 2. OFFAL CONVEYOR : REPAIR 3. FISH BUNKER : REPAIR 4. SORTING M/C : RENEW 5. POTABLE CONVEYOR : REPAIR	04. 2015
13	LANGUSTA	1. GRADING MACHINE 7 : REPAIR 2. CONVEYOR PRODUCTS TO CARO HOLD : REPAIR 3. CARGO HOLD NO.1 : REPAIR 4. FISH HOLD CONVEYOR : REPAIR & MANUFACTURE 5. DISMANTLE FISH FACTORY M/C 6. FILLESTAR - 505L : REPAIR 7. FISH BUNKER : MANUFACTURE 8. FISH FACTORY CONVEYOR : MANUFCTURE	04. 2015
14	MYS DATTA	1. FAN OF MILL HUMMER 2. KNIFE OF HUMMER FAN : SPARE 3. BUSHING OF HUMMER FAN : SPARE	06. 2015
15	OSTROV SAKHALIN	1. INCLINE CONVEYOR : REMODEL	06. 2015
16	PORONAY	1. BELT CONVEYOR : REMODEL	06. 2015
17	POSEYDON	1. CRAB PROCESSING FACTORY - LIFT BUNKER : MANUFACTURE - INCLINE CONVEYOR : MANUFACTURE - BUTCHERING M/C : MANUFACTURE - CRUSHER : MANUFACTURE - HEATER BOILER TANK : MANUFACTURE - BELT/SCAN CONVEYOR : MANUFACTURE - Etc. CRAB PROCESSING EQUIPMENT : MANUFACTURE	03. 2016
18	KAPITAN DEMIDYUK	1. FISH PROCESSING FACTORY - FISH BUNKER : MANUFACTURE - HEAD CUTTING M/C : MANUFACTURE 2. FISH MILL FACTORY - MATERIAL TANK : MANUFATURE - DRYER : INSTALLATION - COOKER : INSTALLATION - Etc. FISH MEAL EQUIPMENT : INSTALLATION 3. CANNING FACTORY - CAN TRANSFER CONVEYOR : MANUFACTURE - Etc. CANNING EQUIPMENT : INSTALLATION	06. 2016
19	GENERAL TROSHEV	1. FISH PROCESSING FACTORY - SCAN CONVEYOR : MANUFACTURE - Etc. CONVEYOR : REPAIR & REMODELING 2. FISH MEAL FACTORY - DRYER : REPAIR & RENEW - PRESS : REPAIR & RENEW - Etc. FISH MEAL EQUIPMENT : REPAIR & RENEW	08. 2016
20	BLANKET	1. LONG LINER FACTORY - FISH BUNKER : MANUFACTURE - KEYSTONE CONVEYOR : MANUFACTURE - BLOCK EJECTOR : MANUFATURE - INSPECTION CONVEYOR : INSTALLATION - BELT/SCAN : MANUFACTURE - Etc. LONG LINER EQUIPMENT : MANUFACTURE	09. 2016

# CRAB PROCESSING LINE

Линия переработки краба



**FISH PROCESSING SYSTEM**  
Линия переработки краба

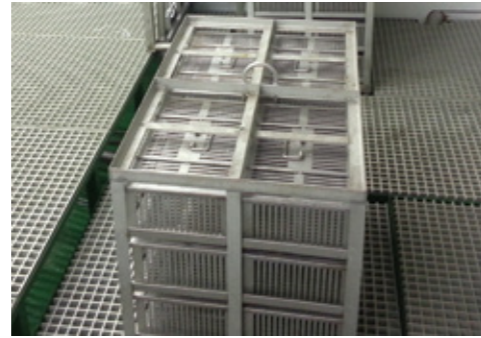

**BASKET CAGE**  
Клетка для корзин

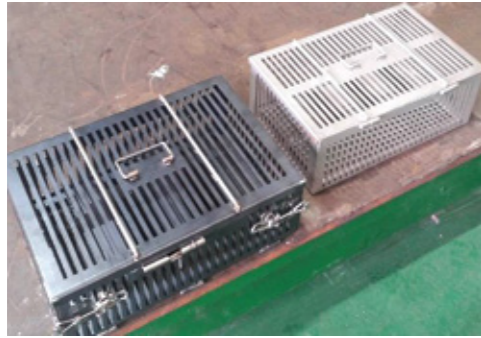

**BASKET ( SUS PLT. TYPE)**  
Корзина (из нерж.)



**BASKET (R/BAR TYPE)**  
Корзина (из кругл.прутка)



**INCLINE CONVEYOR & WORKING TABLE**  
Наклонный конвейер и рабочий стол



**BUTCHERING M/C**  
Разделочная машина



**CRUSHER**  
Дробилка



**HOIST WINCH & RAIL**  
Подъемная лебедка и рельсы

# CRAB ARRANGING SYSTEM

Система аранжировки крабов



**CRAB ARRANGING SYSTEM**  
Система аранжировки крабов



**ROPE WINDER**  
Хребтиноукладчик



**POT LIFTER**  
Устройство для подачи ловушек



**WIRE ROPE**  
Трос



**LINE HAULER**  
Выборочная машина



**POT WINCH**  
Лебедка



**SIDE ROLLER**  
Мальгогер

CM KOREA  
BUSAN KOREA AND IS STRICTLY CONFIDENTIAL  
REVIEWED BY

# TUNA PURSE SEINER

Цех тунцеловного сейнера

# EQUIPMENTS FOR CUSTOMERS

Наши оборудования



**TUNA PURSE SEINER**  
Цех тунцеловного сейнера



**BELT CONVEYOR**  
Ленточные транспортеры



**HYD. TYPE CONVEYOR**  
Конвейер(гидравл.типа)



**TURRET**  
Поворотное устройство



**TURRET**  
Поворотное устройство



**GLAZING TANK**  
Ванна для глазировки



**WINDOW PROTECTOR**  
Защитные плиты для окон

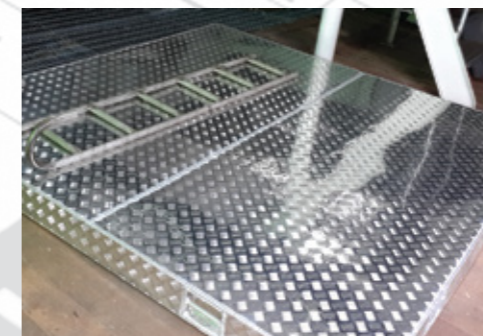

**HATCH COVER & LADDER**  
Крышки люка, трапы

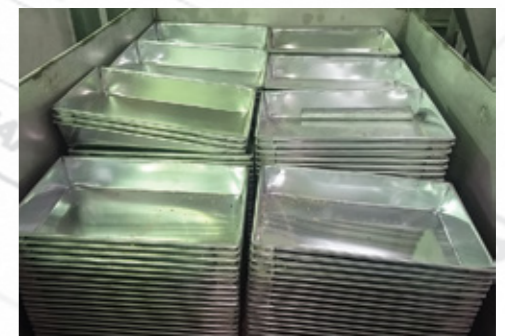

**FISH PAN**  
Блок-формы

CM KOREA LTD. BUSAN KOREA AND IS STRICTLY CONFIDENTIAL  
REVIEWED BY



# SALMON/TUNA PROCESSING LINE

Линия переработки лосося / тунца



**SALMON PROCESSING LINE**  
Линия переработки лосося



**THAWING GIANT SWING**  
Стеллажи для оттайки

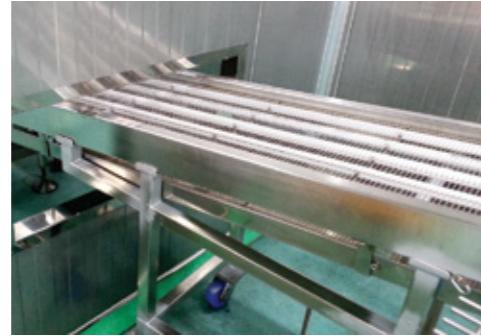

**CONVEYOR SYSTEM**  
Конвейерная система

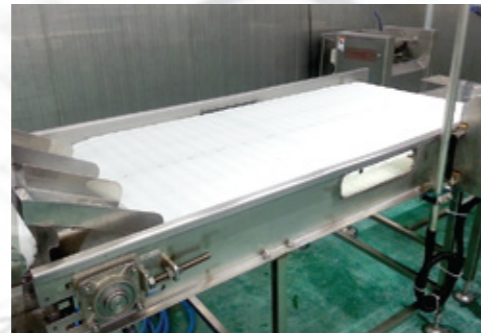

**CONVEYOR SYSTEM**  
Конвейерная система



**WASHING CONVEYOR**  
Моечные конвейера

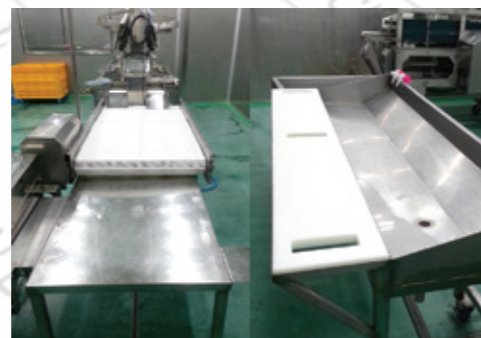

**WORKING TABLE**  
Рабочие столы

# POLLACK PROCESSING LINE

Оборудования для производ.цеха



**HEAD CUTTING CONVEYOR**  
Транспортер с головоотрезающей машиной



**FISH CHUTE**  
Лоток



**BUNKER**  
Рыбный бункер



**WASHING TANK**  
Бункер для замывания рыбы

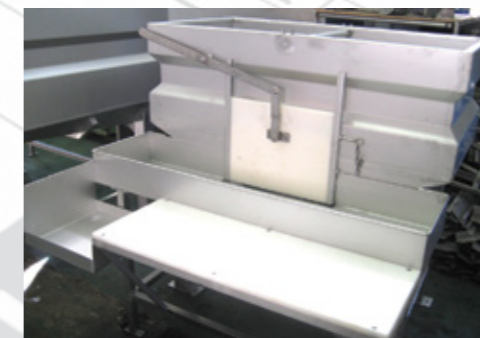

**FISH BUNKER**  
Рыбный бункер



**S-SHAPE CONVEYOR**  
S-образный конвейер (гусиная шея)

# FISH/SHELL PROCESSING EQUIPMENT

Оборудования для переработки рыбы, ракушек

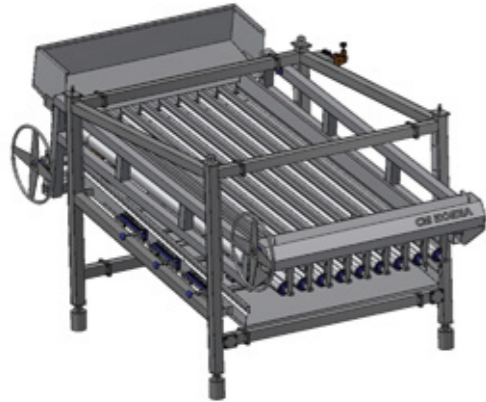

SPECIFICATION	
TITLE	FISH GRADING M/C (HYDRAULIC TYPE . 9ROLLERS
SIZE	LENGTH : 3,900mm WIDTH : 2,180mm HEIGHT : 2,070mm
MOTOR TYPE	OMR50 : 80~100 BAR / 120 R.P.M
CAPACITY	25 TON / hour
MATERIAL	SUS304 / BRASS / M.C / P.E
WEIGHT	1,00 kg

**FISH GRADING M/C**  
Сортировочная машина



**ROPE WINDER**  
Хребтиноукладчик



**9 ROLLERS . HYD./CHAIN TYPE**  
Тип : 9-роликовый, гидравл,цепной



**7 ROLLERS . HYD./CHAIN TYPE**  
Тип : 7-роликовый, гидравл,цепной



**BUTCHERING M/C**  
Зачистная машина

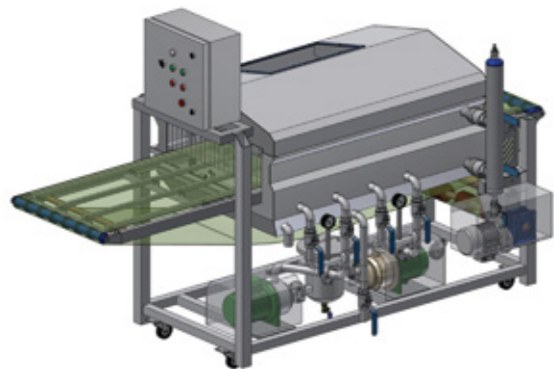

**WASHING CONVEYOR SYSTEM**  
Рыбомоечная машина конвейерного типа

SPECIFICATION	
SPEED OF CONVEYOR	5~10 M/min
MOTOR TYPE	MOTORVARIO 050, 1/60 380V x 50Hz x 0.43kW
CAPACITY	40 FISH transfer/min
TENSION	3 STEP

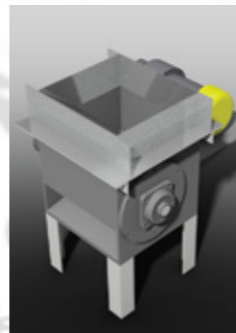

**CRUSHER**  
Дробилка

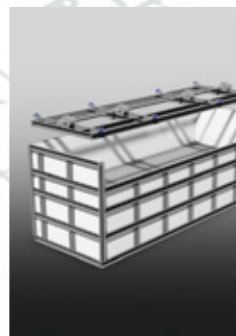

**LIFT BUNKER**  
Подъёмный бункер



# MISCELLANEOUS EQUIPMENT

Оборудования по спец.заказу

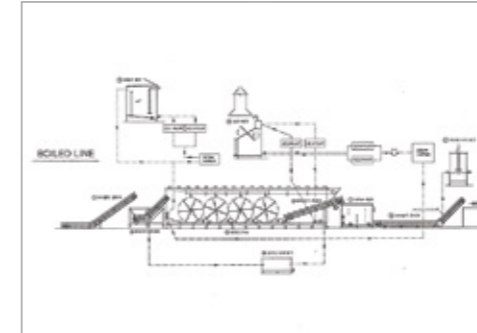

**BOILED LINE LAYOUT**  
Схема варочной системы

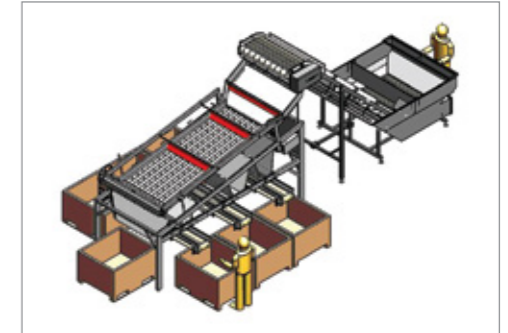

**FISH GRADING LINE**  
Сортировочная линия



**TWIN TRAY CONVEYOR**  
Конвейер с двумя позициями



**FLEXIBLE CONVEYOR**  
Гибкий конвейер

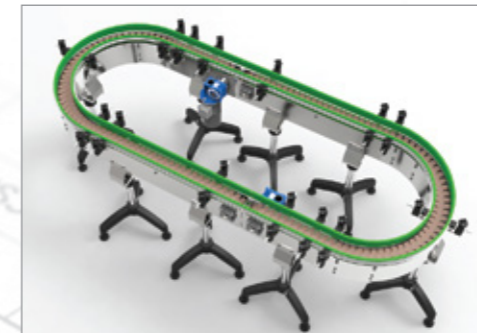

**TURN TABLE CONVEYOR**  
Вращающийся конвейер



**CONVEYOR L-FORM**  
Наклонный конвейер

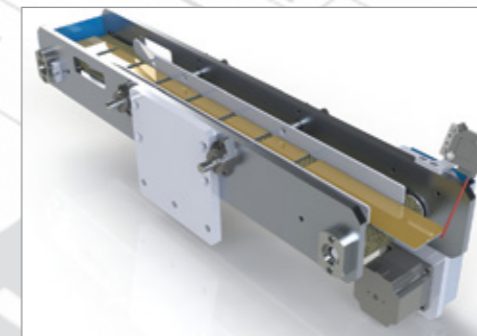

**COMPACT CONVEYOR**  
Компактный конвейер



**MULTI ADJUSTABLE BELT CONVEYOR**  
Конвейер с регулируемой лентой

# PATENT APPLICATION

Подача заявления

# PATENT APPLICATION

Подача заявления

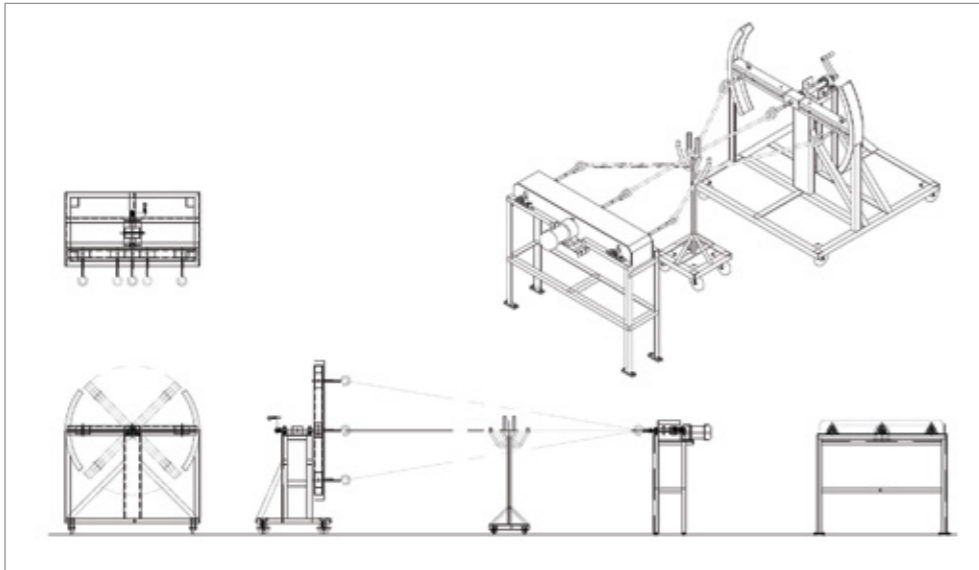

PLAN PROJECTION

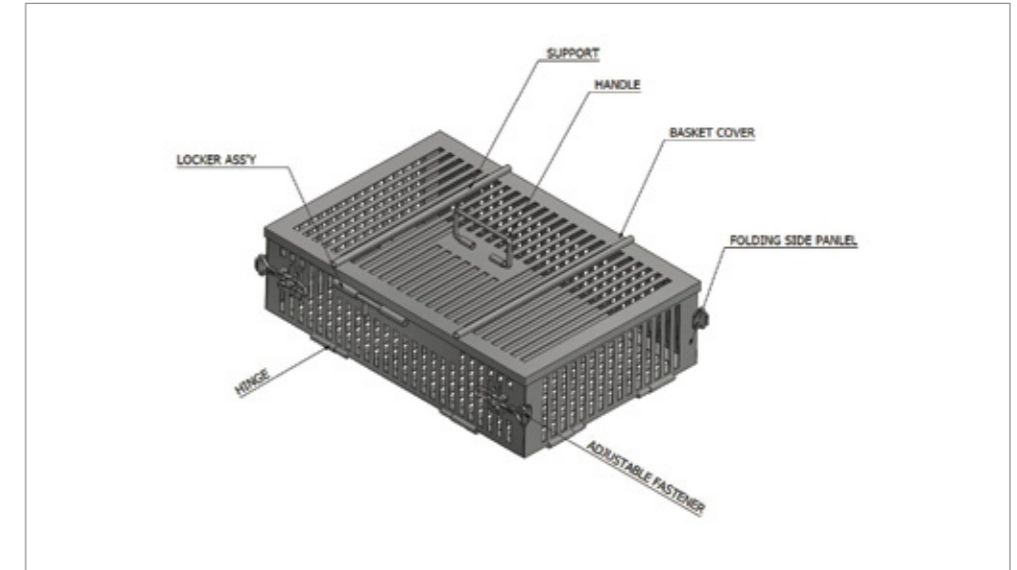

REMOVABLE CASE FOR CHARGING FISHING & FREEZING THE SAME

PATENT APPLICATION NUMBER. 10-2015-0041751



AN AUTOMATIC ROPE TWIST DEVICE

PATENT APPLICATION NUMBER. 10-2015-0047244

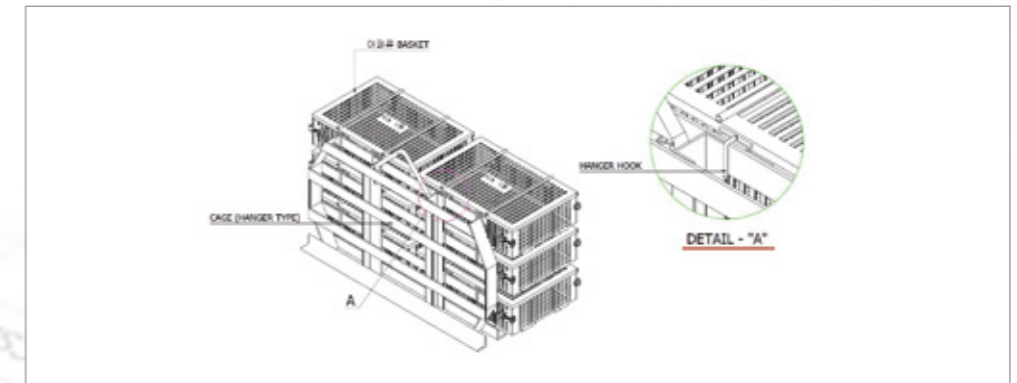

CAGE FOR TRANSFERRING FREEZING BASKET

PATENT APPLICATION NUMBER. 10-2015-0041754



A ROPE FIXED & TWIST DEVICE

PATENT APPLICATION NUMBER. 10-2015-0047245

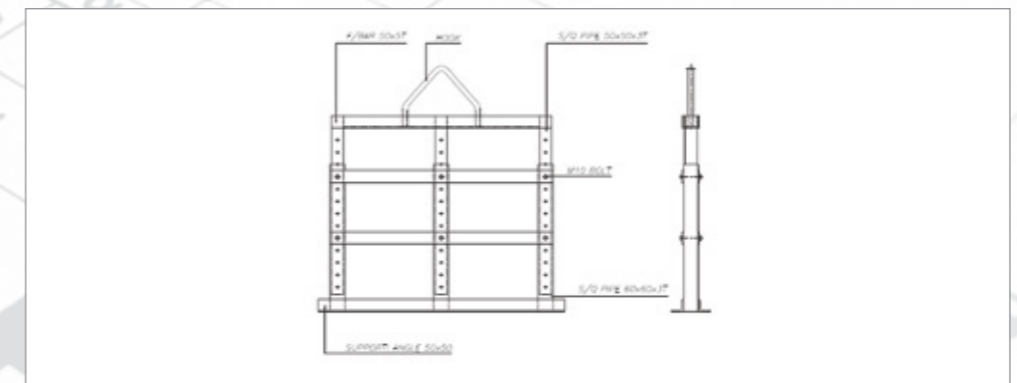

A HEIGHT ADJUSTABLE HANGER TYPE CAGE

PATENT APPLICATION NUMBER. 10-2015-0041639

CM KOREA LTD. BUSAN KOREA AND IS STRICTLY CONFIDENTIAL  
 NOT ALLOW TO REUSE THE INFORMATION WITH OUT OFFICIAL REVIEWED BY

# FISH PROCESSING ENGINEERING

Техническое проектирование перерабатывающего цеха



**GAMCHUN SEAMEN'S CENTER**  
The Place for the Customer's Crews

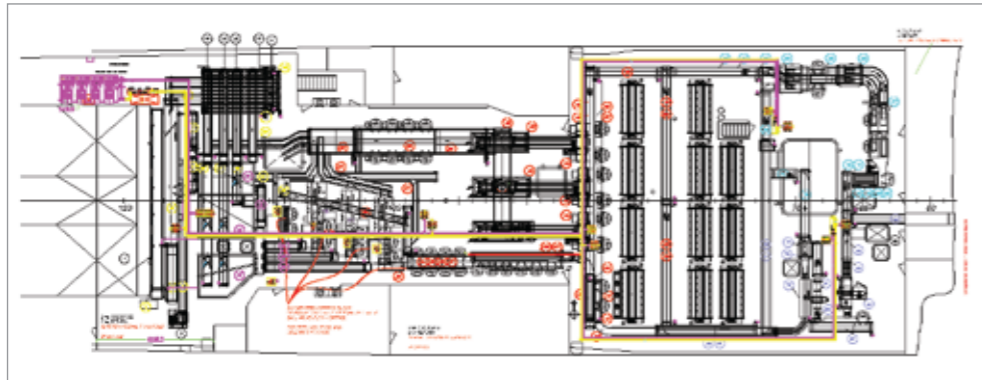

**APPLICATION OF FISH**  
1. POLLACK

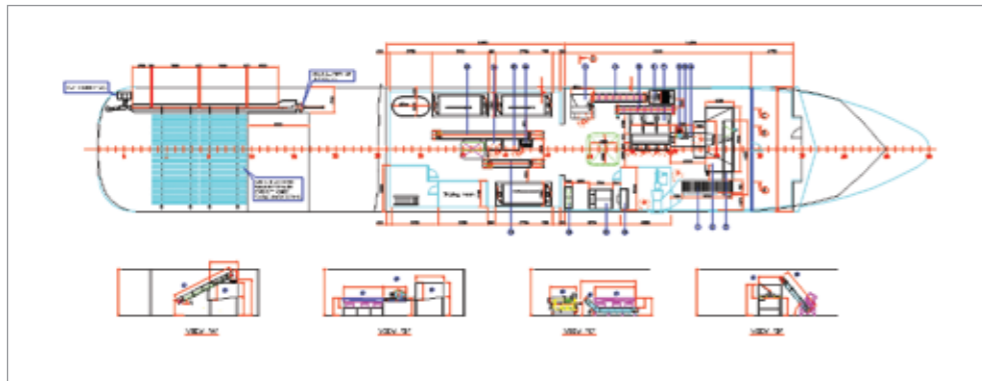

**APPLICATION OF FISH**  
1. POLLACK  
2. COD

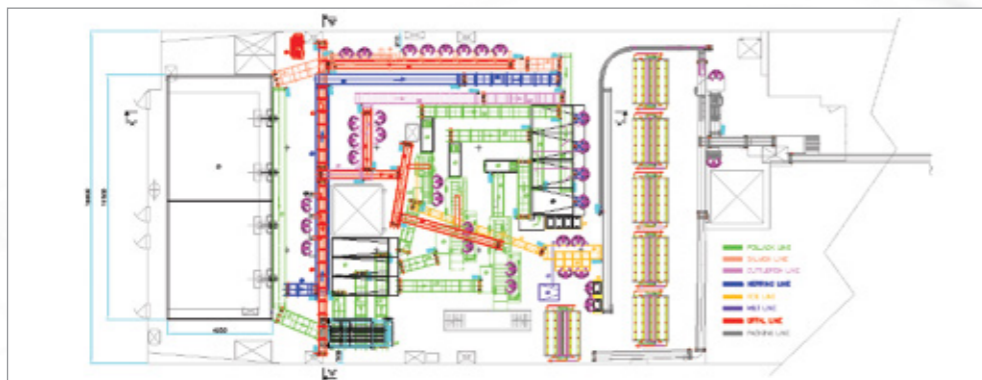

**APPLICATION OF FISH**  
1. POLLACK  
2. COD  
3. SALMON  
4. HERRING

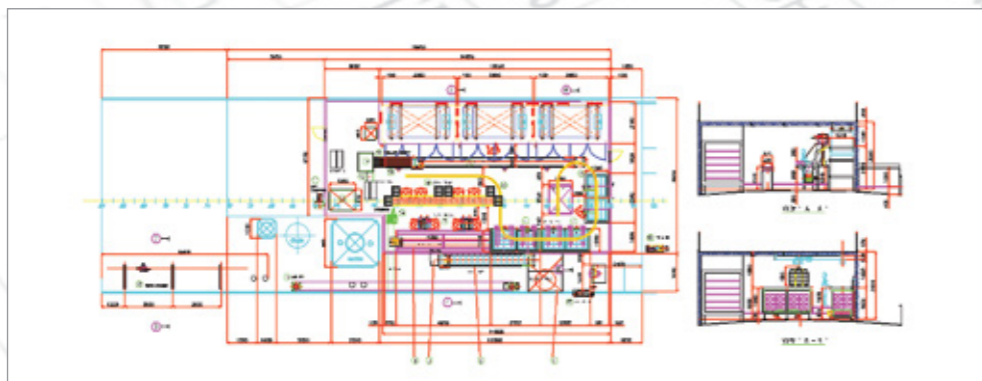

**APPLICATION OF FISH**  
1. CRAB



Sunjin operates Seamen's center for foreign Seamen. Any seamen may visit the seamen's center for relaxing and are not be charged for all services. Further more, the center offers service for free including, haircut and massage. Foreign seamen have payed high compliments our Seamen's center.



## Facilities

- Facilities (Abt. 835m<sup>2</sup> : Lounge-340m<sup>2</sup>, Gym-495m<sup>2</sup>)
- Seamen's Lounge - Teas, Drinks, Bread for free
- Internet Cafe - Skype phone service, 10PCs
- Shower Stalls - Separate Dressing room
- Laundry - Washing machines, Dryers Dental Clinic, Barbershop
- Exchange Service
- Satellite Television, Public Telephone Massage Machines
- Table-Tennis Tables, Billiard Tables, Darts
- Mini Soccer Game Table



CM KOREA LTD. BUSAN KOREA AND IS STRICTLY CONFIDENTIAL  
REVIEWED BY

# Affiliate

Линия переработки краба



## SUNJIN ENTECH CO., LTD.

Sunjin Entech Co.,Ltd. (established in 1995) provides total ship repair services for both domestic and overseas ships with 320m pier & docking facilities. Particularly, the company possesses every equipment and component for ship repair. The company mainly operates repair and reconstruction for vessel machineries, oil-pressure gears, fishing equipment, hulls and plumbing fixtures. Fishing ships, cargo ships, oil tanker, chemical tanker ships and all other kinds of ships are our main customers.



## SUNJIN SHIPBUILDING CO., LTD.

Sunjin Shipbuilding Co.,Ltd. is able to accommodate 1,000 ton of 4 ships(vessels) in the 1st dockyard and a 2,000 ton ship (vessel) in the 2nd dockyard at the same time. The company possesses wide experience and know-how for ship repair with 50 years of company history. We repair and reconstruct about 200 ships per year.



## SUNJIN JONGHAP CO., LTD.

Sunjin Jonghap Co., Ltd. was established in January 1997, located in Busan, Korea. Since then, we are a leading company to repair and supply parts completely for all kinds of high speed engines with well-educated technicians and high quality equipments. We are giving the best overhaul service with our own capability and equipment for Cummins, Caterpillar, Detroit Diesel (GM), Daewoo, Ruston, Deutz, MWM and MITSUBISHI etc. We have been receiving the good reputation from our customers, who are fishing companies, oceanic construction, Russia national shipping, and the government's vessels and cruisers etc. Sunjin Jonghap is always ready to do our best service for customers at anytime and anywhere with our own national network.



## HYDRO KOREA CO., LTD.

Hydro Korea Co., Ltd. tries to support customer by supplying technical solution related hydraulic equipment through long term experience in ship repair market.



### Sunjin has Brilliant History for ship Repair.

Sunjin has Pier & Docking Facilities and over 50 years experience as Total Ship Repair Service of Engines, Hull, Hydraulic Equipment, Piping Work and So on. We are able to Provide One-stop Service to meet Customers' needs.

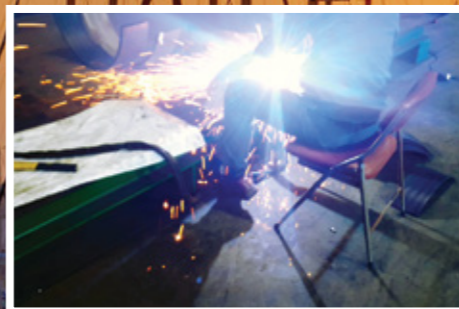

**Absolute  
Best Partner!**

## HEAD OFFICE / FACTORY

Address. #14, 405beon gil, Gamchunhang-ro, Saha-gu, Busan, Korea  
Tel. +82-51-262-3554 / Fax. +82-51-262-3556 / e-mail : cmkorea@sunjinckm.com